

Dear user,

Thank you very much for purchasing LS533H rotary laser. Please read this instruction manual before operating it.

## Contents

1. Features and Functions
2. User Safety
3. Nomenclature
4. Operation guide
5. Applications
6. Self-Check and Calibration
7. Technical Specifications
8. Maintenance

### 1. Features and Functions

LS533H full automatic leveling rotary laser could project visible auto-leveling horizontal plane and project laser slope by setting accurate grade value. It provides exact horizontal and grade preference for indoor and outdoor construction sampling and calibration with convenient operation and wide usage.

#### Features

- ※ 360°rotating, electronic leveling, laser stop rotating and sound indication when out of range.
- ※ Slope scanning function could set the grade value for the axis accurately.
- ※ TILT mode has the unlevelled alarm function, the laser head stop rotating to insure the construction accuracy when the instrument is hit.
- ※ VWS mode could set the instrument to be low sensitive, to insure the reliable wild working performance.
- ※ LCD display with backlight illumination
- ※ Accuracy self-calibration function
- ※ Sleep function
- ※ Able to connect with the tripod through the 5/8" screw thread
- ※ Various accessories of elaborate design can bring usage expansion※ Rainproof and dustproof

### 2. Usage safety

- ※Laser output sign lies at the output aperture.
- ※Do not stare into laser beam directly
- ※Do not disassemble the instrument or attempt to perform any internal servicing. Repairs and servicing could be performed only by authorized service centers.
- ※The instrument complies with the safety classification standards of laser radiation

### 3. Nomenclature



### 4. Operation Instruction

#### 4.1 Battery installation

a) Put 3\*C alkaline batteries into the battery box follow the marked polarity direction, and install the battery box to the instrument.



Install the alkaline battery box

b) Mount the rechargeable battery box onto the instrument directly



Install the rechargeable battery box

#### 4.2 Charge the rechargeable battery

Charge the rechargeable battery directly by insert the charger into the charging jack. The LED is red during the charging process; the LED will turn green when the battery is full.

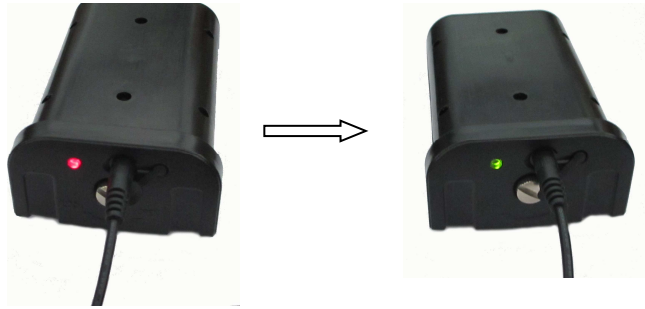

Charge the rechargeable battery box directly



Charge the rechargeable battery box on the instrument

#### Note:

- a) Please charge the rechargeable battery when the battery is empty. That could extend the battery service life.
- b) Please charge the rechargeable battery every 2-3 months since the instrument leaving factory.

#### 4.3 Instrument placement

- a) Place the instrument on the platform directly





- b) Install the instrument on the tripod by the 5/8" screw thread

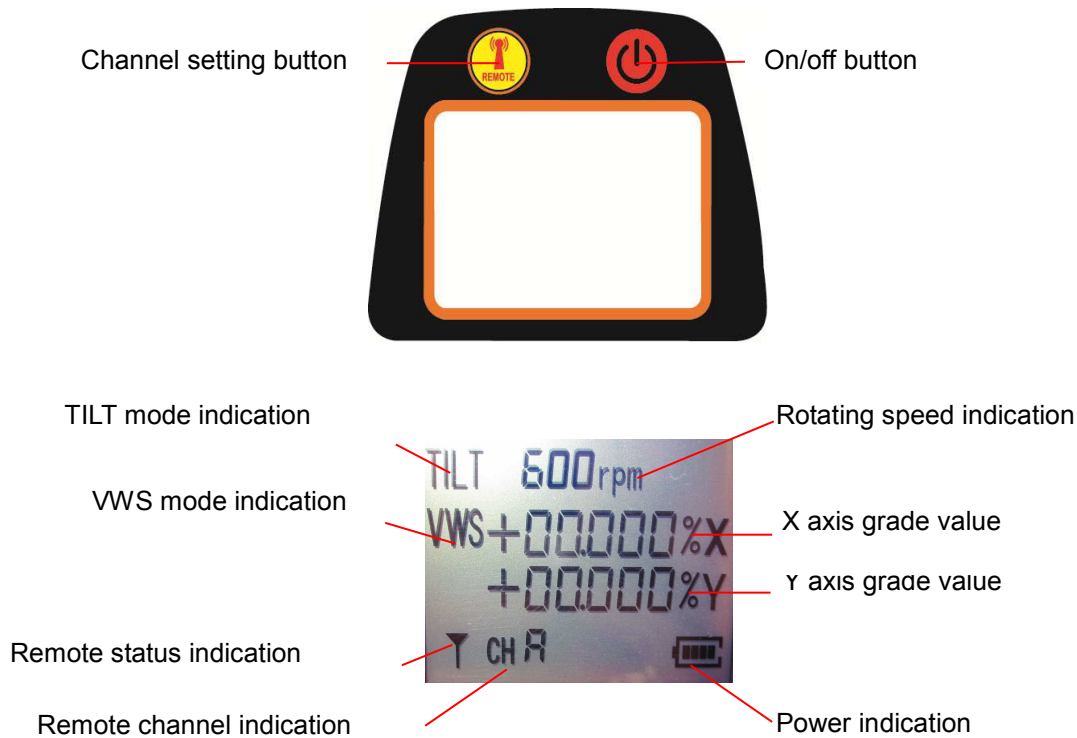

## 4.4 Keypad



### 4.5 On/off button

- Press ON/OFF button, power on the instrument, LCD will display the current status.
- After powering on the instrument, it will test the volume and LCD will display the corresponding battery volume status.
- After powering on the instrument, it is in auto-leveling status, after the auto-leveling, the rotation speed is 600rpm.
- After powering on the instrument, TILT mode is preparation status (TILT symbol flash slowly), after auto-leveling, if there is no vibration within 30 seconds, TILT mode will activate.
- After powering on the instrument, the grade value will display as +00.000%.
- After powering on the instrument, if there is the remote control work with it, the status of remote controlling status will display , if there is no remote control work with it, it will display .



### 4.6 Remote control channel setting button

Press this button to switch the remote control channel circularly(from CH2 to CHF).

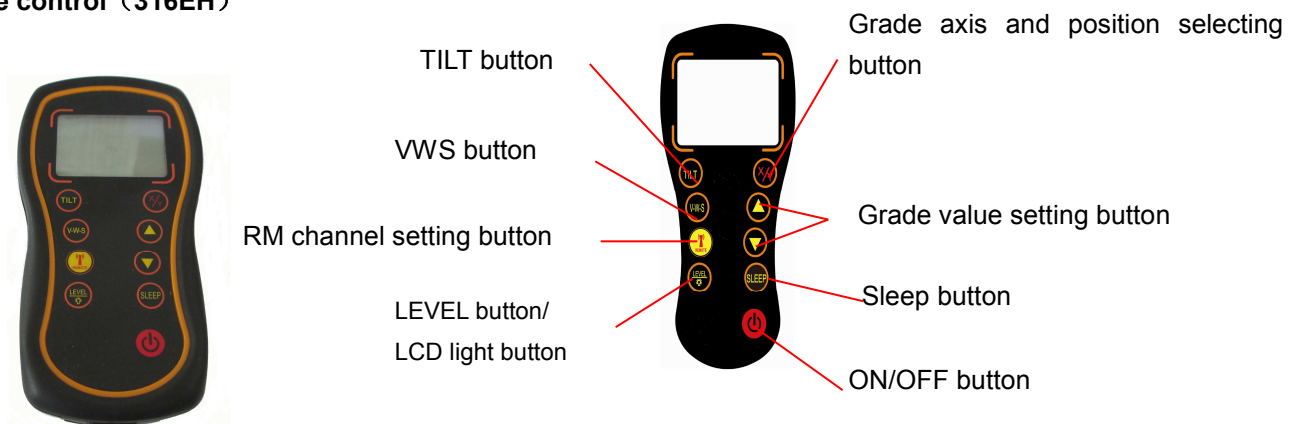
### Remote control (316EH)



#### 4.7 Grade axis and set position selection button

- Long-press this button (hold more than 2 seconds), enter the X-axis grade setting mode, the X axis symbol (+) will flash. Then short-press this button could move the cursor (the selected position will blink). Press   button to change the symbol position or value
- When X axis setting is done, long-press this button to enter the Y-axis grade setting mode, the Y axis symbol (+) will flash, setting method is same as X axis.
- After Y axis grade setting is done, long-press this button to confirm the grade setting, instrument will exit the grade setting mode and start to work under the set grade value.

#### Note:

If there is no operation in 8 seconds in the grade setting mode, the instrument will confirm the current grade setting data automatically.

#### 4.8 TILT mode button

TILT mode is used for keeping the construction high accuracy. When instrument is in the TILT mode, if it vibrates a little bit, the instrument will alarm to indicate user.

- There are 3 status in TILT mode: TILT preparation, TILT working on, TILT touching off,
- Press this button to enter the TILT preparation status or exit TILT mode.
- When instrument is in TILT preparation, TILT symbol on the display will flash slowly, if there is no vibration in 30 seconds after instrument is leveled, TILT will start to work. That symbol on display becomes stable.
- When TILT mode is working on, if the instrument vibrates, then TILT will be touched off. The laser head will stop rotating to flash, TILT symbol on the display flash quickly, instrument will not self-level again.
- When the TILT mode is touched off, press TILT button to exit TILT mode, or press  button to enter the auto-leveling mode.

#### 4.9 VWS mode button

VWS mode (anti-vibration mode) is used for keeping the construction stable. When instrument is VWS mode, if instrument vibrates a little bit, instrument will not stop rotating and keep auto-leveling, if the vibration is big, instrument will start to alarm.

- Press this button to enter the VWS mode or quit.
- When instrument enters the VWS mode, it will turn on the TILT mode automatically at the same time.
- When the vibration is big in the VWS mode, instrument will stop rotating to flash, TILT symbol on the display flash quickly, instrument will not self-level again. User could press VWS button only to exit this mode.

#### 4.10 LEVEL/ LCD illumination button

Short press this button to make the instrument auto-leveling again, hold on this button to power on/off LCD illumination button

#### 4.11 Sleep button

- Press this button to enter the sleep mode, instrument stop working.
- When instrument is in sleep mode, all other buttons will be invalid except  button.
- Instrument will work in original working state after exiting the sleep mode.

#### 4.12 Power indication

After powering on the instrument, the instrument will test the battery volume automatically, and LCD will display the battery volume status.

 Indicates the battery volume is full

 Indicates the battery volume is nearly full



Indicates the battery volume is a little low



Indicates the battery volume is very low, charging is suggested.



Indicates the battery volume is empty, need charging.

During using 316EH to work with LS533H, when the instrument display , means the remote control function of instrument is on, but there is no matched remote control (the possible cause is: 1) the remote control is off. 2) the distance between the remote control and instrument is too far---over 70m. 3) There is interference between the remote control and instrument. 4) The channel of instrument does not match the remote control.)

When displaying , means the communication of remote control is normal.

**Note:**

The battery volume symbol on the remote control means the battery volume of remote control, not the battery volume of instrument.

**5. Self-check and calibration**

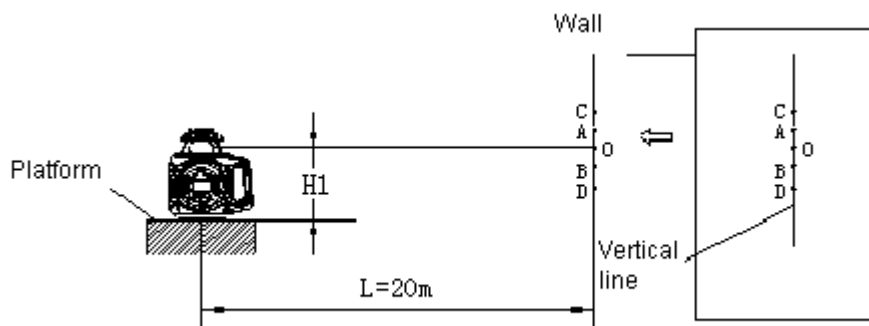

The instrument must be self-checked after using for a certain time or before operating in a major project. If the accuracy is found beyond tolerance, please make adjustment according to methods as follows.

**5.1 X, Y axis accuracy test**





- Put a table 20m far away from the wall indoors and place the instrument on the table with the X-axis faced the wall.
- Power on the instrument, after auto-leveling, mark A on the laser line on the wall, make a vertical line along A.
- Measure the distance H1 from the horizontal laser plane level to the platform.
- Turn the instrument by 90° by turn, after auto-leveling, mark the point of intersection of the laser line and vertical line as B, C, D separately.
- Measure the maximum h among A, B, C, D, and mark the center point of two points (the distance between them are biggest) as O.
- If  $h \leq 2\text{mm}$ , the instrument accuracy is qualified, if  $2\text{mm} < h \leq 10\text{mm}$ , the accuracy is out of tolerance, please make the accuracy calibration by yourself, if  $h > 10\text{mm}$ , the instrument accuracy is out of tolerance, please contact the distributor for servicing.

**5.2 X, Y axis accuracy calibration**

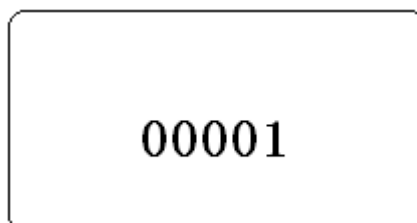
- In power off status, press and hold  button on the main unit, then press ON button, keep holding  button after power on, now LCD will display the count down(as following figure).



b) From the 3<sup>rd</sup> seconds, LCD will display the entrance of the inner menu, if release  button now, the instrument will enter the corresponding menu.

c) From the 3<sup>rd</sup> to 5<sup>th</sup> seconds is the entrance of the horizontal calibration interface, release  button will make the instrument enter horizontal calibration. From 6<sup>th</sup> seconds, it is leave factory setting interface, customers do not enter this mode.

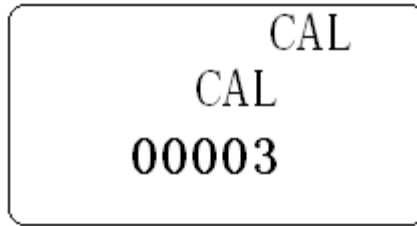

a) Press  button on the remote control to choose the axis need to be calibrated.

b) Press  button on the remote control to move the laser line up and down, until it coincide with reference dot O.

### 5.3 Calibration confirmation

When finished calibration, press  button on the remote control to save the calibrated value.

#### Note:

- Under CAL self-calibration mode, the self-calibration coefficient of the axis would be around 1600~2495, if the accuracy could not meet with requirement after calibration within this range, please contact the service center or distributor for service.
- After calibration, instrument needs to be power off and re-power on, then the calibration can be effective then.
- While making X, Y axis calibration, after calibrate X axis, Y axis accuracy check is necessary, and after calibrate Y axis, X axis accuracy check is necessary, until both X,Y axis accuracy meet the requirement, the calibration is finally finished.

### 6. Technical specifications

Item	Parameter
Laser wavelength	635nm
Laser class	class II /III
Output range	600m
Rotation speed	600rpm
Horizontal accuracy	±0.05mm/m
Grade accuracy	±0.4mm/m
Grade range	X axis: -10%~+10% Y axis: -10%~+10% Double axis: $ X + Y  \leq 14\%$
Leveling range	±6°
Temperature range	-10°C ~ +45°C
Storage temperature	-20°C ~ +70°C
IP	IP65
Power	3*C battery or Li rechargeable batteries
Size	212×168×212mm
Size	2.1Kg (with batteries)

## 7. Applications

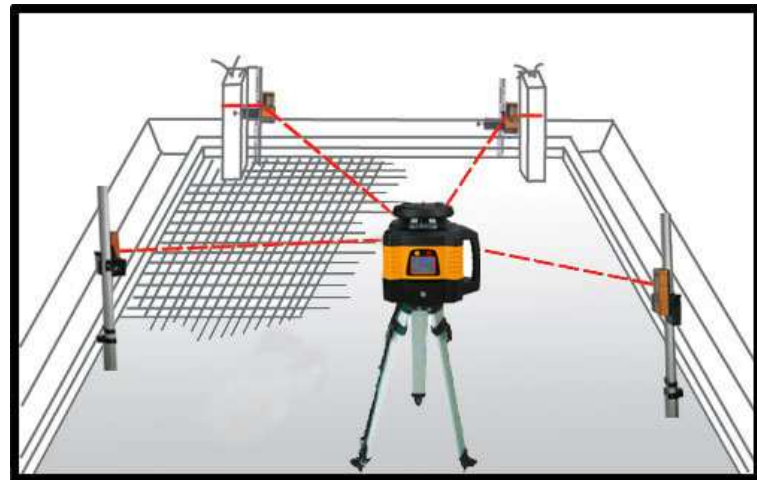
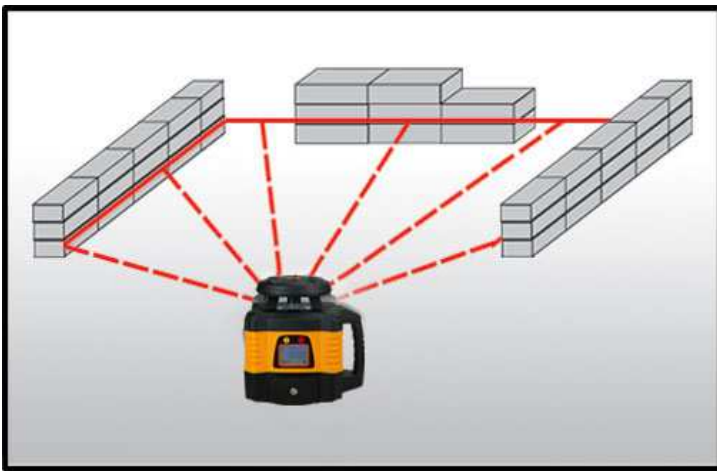
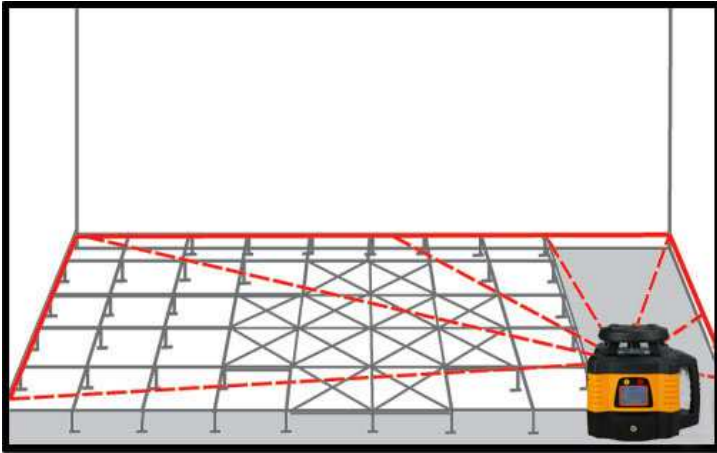

## 8. Maintenance

- The instrument should be carefully operated and properly preserved, and any violent shock or falling will possibly result in the damage of instrument.
- Do not attempt to disassemble the instrument, and the unprofessional disassembly will result in the damage of instrument.
- Keep the cleanness of instrument, especially the laser output window, and remove dust by the gentle operation of soft clean cloth.
- Take the batteries out when the instrument is not in use for extended time, and keep the instrument in the carrying case when it is unused.
- Waterproof design, however, please don't make the instrument use in rainy day and wet environment as possible as you can.